

MACHINES FOR TRADE

THE KEY TO SUCCESS FOR PREMIUM PRODUCTS

W 130 / WW 130

ME 130 N / ME 250 N

K 65 / K 130 / KCU 200 / K 60 VAC / K 130 VAC



APPLICATIONS THE TRADE MACHINES

LASKA trade machines are suitable for smaller production quantities to medium batch sizes. They are also the equipment of choice when new products are to be developed. The range of products includes all important machine groups and applications: cutting, mixing, mincing, emulsifying. Customers use the trade machines to produce:

- › Boiled sausage
- › Raw sausage
- › Cooked sausage
- › Pies
- › Fish
- › Soups and sauces
- › Cheese and butter
- › Fruit and vegetable products
- › Pet food
- › Sweets

STRENGTHS AND BENEFITS

LASKA trade machines are appreciated for their various features and the special challenges they are expected to meet. The most important aspect is the easy and reliable processing of your premium products.

QUALITY PROVEN IN USE

Just like all other LASKA machines, the trade machines are made of solid stainless materials. They meet strict hygienic requirements and are easy to clean. The design allows for the unusual operating conditions and provides easy and safe operations as well as good access for servicing.



LASKA GRINDERS

YOUR BENEFITS AT A GLANCE

OPERATION

- › Easy handling and user-friendly, robust operating elements
- › Easy and quick exchange of cutting set
- › Ergonomic operation

HYGIENE AND SAFETY

- › Polished surfaces for highest possible hygienic standards
- › Closed base plate prevents contamination of the machine interior
- › Cleaning ducts provided with special sealing to ensure perfectly hygienic cleaning (applies only to WW 130)
- › Clearly arranged control system and high operating safety
- › Safety equipment for optimum working safety

ELECTRICAL EQUIPMENT

- › Low current consumption due to state-of-the-art drive and control technology
- › Integrated control box ensures compact design as well as long service life of electrical components

DESIGN

- › Compact and space-saving design with integrated control box
- › Long service life
- › Low operating noise
- › Low wear of cutting set minimizes costs
- › Attractive and elegant design

SERVICE AND MAINTENANCE

- › Minimum maintenance required due to proven, field-tested machine concept
- › Easily accessible inspection doors
- › Worldwide service network and competent support on all continents

PRODUCTION

- › High number of various cutting sets depending on product requirements
- › High hourly rate
- › Gentle and continuous material loading
- › Low heating of material to be cut
- › Excellent cut
- › Perfect self-unloading down to the cutting set

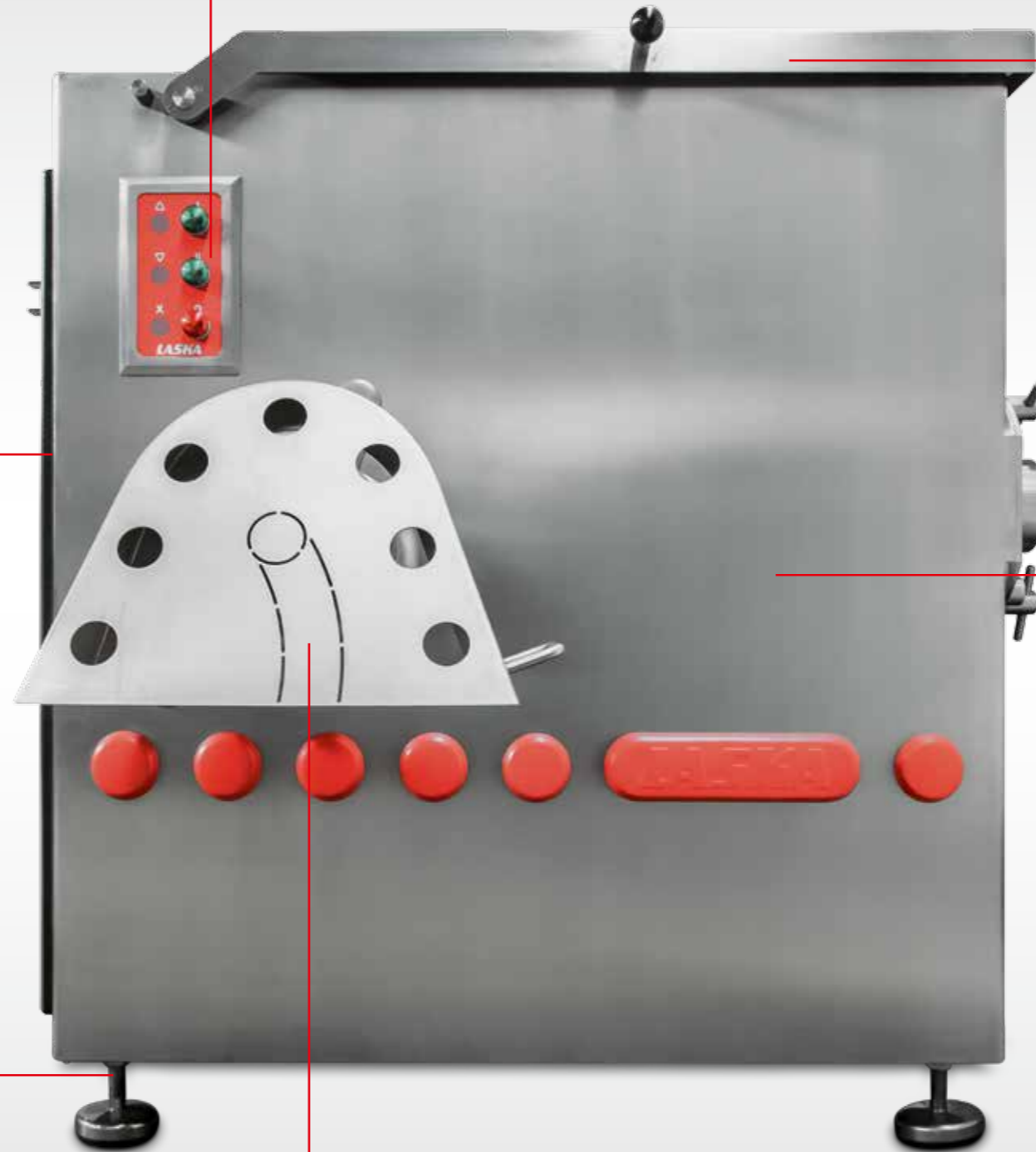

LASKA GRINDERS - OVERVIEW



FILLING GRINDER W 130

- › Hopper volume 42 litres
- › Working worm with worm pull-out device
- › Easy loading

ANGLE GRINDER WW 130

- › Hopper volume 175 and/or 295 litres
- › LASKA angle structure: feed worm conveys material to be cut gently and evenly to the working worm
- › Easy loading

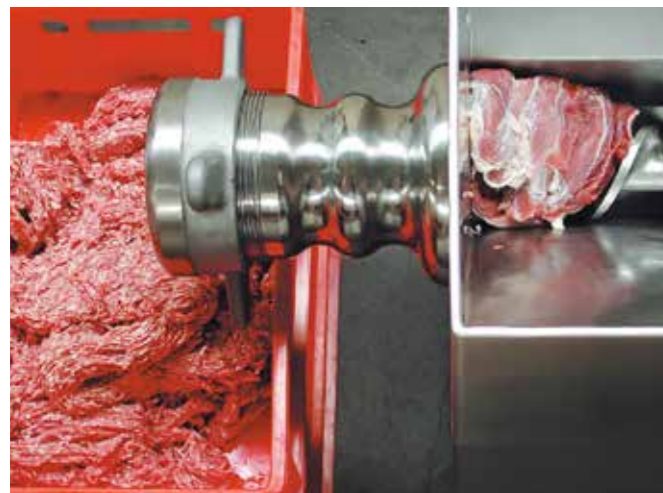

APPLICATION W 130

- › Production of all types of premium quality sausages
- › Clear clean cut, no crushing and smearing
- › Low heating of material to be cut

APPLICATION WW 130

- › Production of all types of premium quality sausages
- › Clear clean cut, no crushing and smearing
- › Low heating of material to be cut
- › Very quick and complete unloading of the loadinghopper due to angle structure



EQUIPMENT FOR YOUR LASKA GRINDER



EASY LOADING

- › Large loading hopper
- › Ergonomic loading height

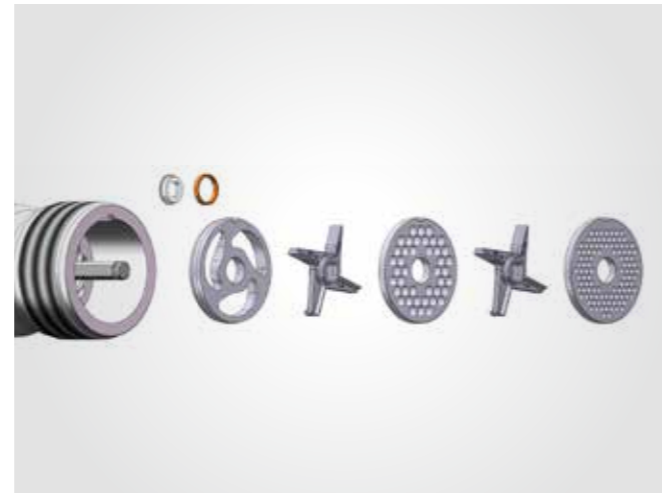

CUTTING TOOLS

- › Fresh meat cutting set: for processing fresh meat (up to -4 °C)
- › Desinewing cutting set: for eliminating scraggy and hard parts
- › Defrost cutting set: for processing slightly frozen meat (up to -10°C)
- › Frozen meat cutting set: for processing frozen meat and for coarse granulation

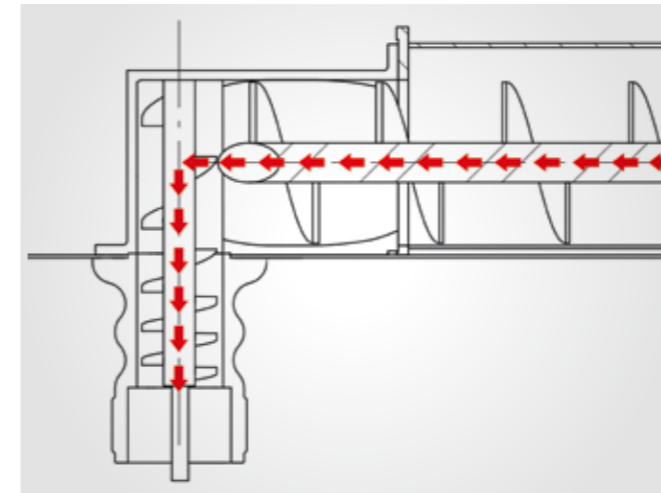

ANGLE STRUCTURE

only WW 130

- › Material is gently taken by the feed worm and conveyed continuously to the working worm
- › High hourly rates
- › Gentle treatment of the material to be processed
- › Low heating of material to be cut
- › Robust and quiet

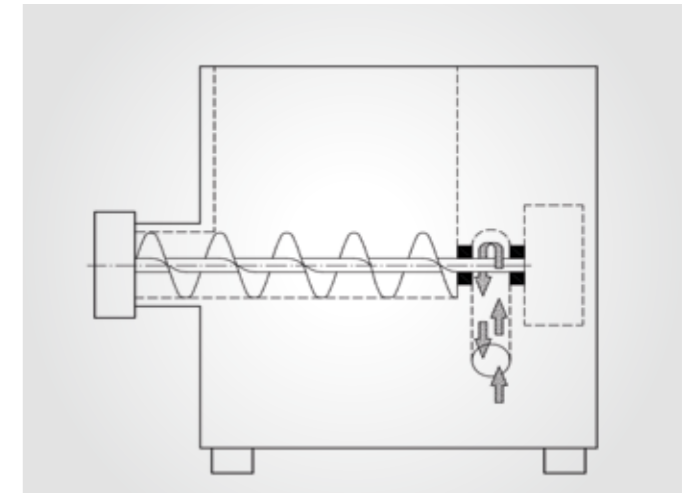

HYGIENE

only WW 130

- › Double sealing between product and drive areas
- › Product areas are reliably protected against the penetration of bearing lubricants and/or gear oils
- › Drive areas are reliably protected against the penetration of product residues



COMPLETE UNLOADING

- › Perfect self-unloading in case of product changeover and/or at the end of production due to the special geometry of the worm housing and worm
- › Facilitates cleaning of the machine
- › Maximum utilization of raw materials



ELECTRICAL EQUIPMENT

- › Low current consumption due to state-of-the-art drive and control technology
- › Easy to operate due to clearly arranged control system
- › Robust special driving motor with motor protection device
- › Easy and clearly arranged relay control for high operational reliability



OPTIONS FOR YOUR LASKA GRINDER



SAFETY COVER FOR CUTTING SET

required for CE marking

- › Hinged and electrically interlocked
- › Machine can be switched on only if safety cover is closed



ENLARGED GRINDER HOPPER WITH MIXING SYSTEM

only WW 130

- › Paddle mixing shaft or Z-mixing arms
- › Machine with enlarged hopper
- › For mixing in of ingredients and/or for salting
- › Gentle treatment of mixture (interval switching possible)
- › Prevents bridging in the mincing hopper



DESINEWING FACILITY FOR FRESH MEAT

- › Automatic elimination of hard parts and unwanted materials such as sinews or gristles from the product to be cut
- › Desinewing facility with desinewing cutting set
- › With adjustable discharge pipe for the desired degree of separation



HYDRAULIC LOADING FOR 200 LITRE STANDARD TRANSPORT TROLLEY

only WW 130 with machine elevation

- › Including enlarged hopper with a volume of 295 litres
- › Easy to operate
- › Stainless, hydraulic
- › Robust, low-maintenance, and durable due to hydraulic drive



HYGIENE AND SAFETY

- › Polished surfaces for highest possible hygienic standards
- › Closed base plate prevents contamination of the machine interior
- › Knife hood swings wide open, providing good accessibility for knife change and cleaning
- › Clearly arranged control system and high operating safety
- › Safety equipment for optimum working safety

OPERATION

- › Easy handling and user-friendly, robust operating elements
- › Control panel with membrane keyboard and plain text display - with touch screen on request
- › Noise protection cover of acrylic glass - or stainless steel on request
- › 4 infinitely variable and freely selectable speeds for perfect product adaptation
- › Perfectly accessible knife head due to knife hood swinging open wide
- › Mixing cycle forward and reverse

THE LASKA CUTTER

YOUR BENEFITS AT A GLANCE

PRODUCTION

- › Excellent cut
- › Infinitely variable knife shaft speed
- › High hourly rate

**ELECTRICAL EQUIPMENT**

- › Low current consumption due to state-of-the-art drive and control technology
- › Programmable logic controller with microprocessors
- › Low-maintenance three-phase AC motors
- › Control box integrated in the machine housing

SERVICE AND MAINTENANCE

- › Easily exchangeable knives
- › Low-wear special sealing of the knife shaft
- › Minimum maintenance required due to proven, field-tested machine concept
- › Easily accessible inspection doors
- › Worldwide service network and competent advice on all continents

DESIGN

- › Compact and space-saving design with integral control box as an option
- › No bending stress on knife shaft, since the bearing is located exactly within the axis of the belt force
- › Cutter bowl with reliable true-running accuracy
- › Long service life
- › Low operating noise
- › Attractive and elegant design

LASKA CUTTERS - OVERVIEW



CUTTERS
K 65 / K 130

- › Bowl volume 65 and/or 130 litres
- › Low-maintenance three-phase AC motor, either 22 kW or 60 kW
- › Microprocessor control with automatic error diagnosis - for increased operational reliability and easier maintenance
- › Knife head units quick and easy to insert



VACUUM CUTTERS
K 60 VAC / K 130 VAC

- › Bowl volume 60 and/or 130 litres
- › Low-maintenance three-phase AC motors, either 22 kW or 60 kW
- › Stainless vacuum cover, knife hood, pneumatic
- › Vacuum version minimizes entrapped air



COOLCUTTER
KCU 200

- › Bowl volume 200 litres
- › Low-maintenance 90 kW three-phase AC motor
- › High hourly rate
- › Microprocessor control with automatic error diagnosis - for increased operational reliability and easier maintenance
- › Knife head units quick and easy to insert



APPLICATION
KCU 200

- › Processing of both fresh meat and frozen meat
- › Processing of large chunks without pre-grinding
- › Excellent cut and even granulation
- › Extreme degree of fineness with maximum protein yield



APPLICATION
K 65 / K 130

- › Processing of both fresh meat and frozen meat
- › Processing straight from the chunk, without pre-grinding
- › Excellent cut and even granulation
- › Extreme degree of fineness with maximum protein yield



APPLICATION
K 60 VAC / K 130 VAC

- › Intensive, even reddening
- › Improved quality and longer shelf life
- › Attractive appearance and improved taste
- › Vacuum lid with feed window permitting observation of cutting procedure



K 65



EQUIPMENT FOR YOUR LASKA CUTTER



KNIFE SHAFT

- › Infinitely variable speed
- › 4 freely programmable fixed speeds
- › Special bearing technology and seals for highest speeds and high operating safety
- › Low-wear special seals
- › No bending stress on knife shaft
- › Long service life of bearings and seals



KNIVES

- › Optimum knife shape depending on product requirements: universal knife FL (boiled, cooked and raw sausage), special knife FLT and/or FLTH (extra-fine emulsions and rind processing), special knife FLR (raw sausage)
- › Minimum distance between cutter bowl and knives
- › Unequalled edge-holding property and premium cut
- › Easy and quick knife change



MIXING CYCLE

- › Gentle mixing of chunks or ingredients into the sausage meat
- › Infinitely variable forward and reverse
- › Optimum sausage meat ventilation
- › Maintaining the grain size and texture on unloading



VACUUM VERSION

only K 60 and K 130

- › Time, duration, and degree of vacuum freely selectable as a function of the product and the operating mode
- › Entrapped air is minimized
- › Clear cut
- › Intensive, even reddening
- › Flavour is kept
- › Smaller volume of sausage meat means less casing required



KNIFE HEAD

- › Knife head easy and quick to install
- › Optionally up to 6 knives to be inserted
- › Best access to knife head for knife exchange
- › Knife balancing device avoids imbalance and vibrations (K 130 and KCU 200)



KNIFE HOOD

- › Solid double-jacket construction
- › Spring-borne sealing easy to dismantle for cleaning
- › Knife hood hydraulically operated (KCU 200)

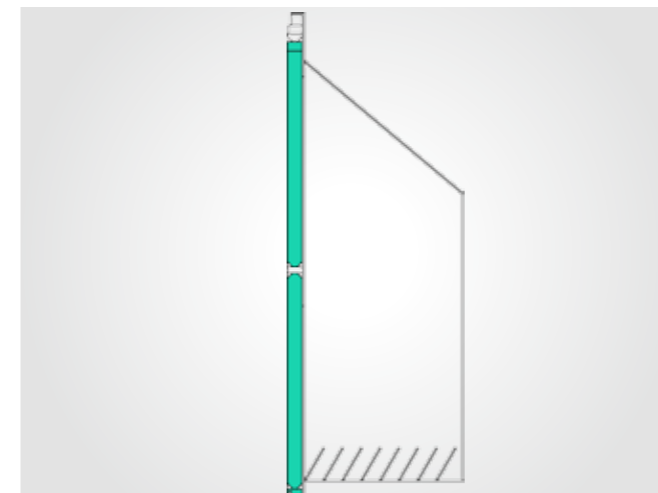

AIR FILTER SYSTEM

- › Integral filter mat in the machine lid for coarse filtering
- › No thermal short-circuit through specific routing of air flow in the machine
- › Interchangeable filter



ELECTRONIC EQUIPMENT

- › Compact, hygienic design due to integral control box
- › Low current consumption due to optimized control and drive technology
- › Separate fan for dissipation of heat from machine interior
- › Permanent monitoring of voltage, current consumption, speeds, and temperatures

OPTIONS FOR YOUR LASKA CUTTER



SAUSAGE MEAT EJECTOR

- › Quick unloading of bowl
- › Hydraulic movement in and out at the push of a button (K 130 optional, KCU 200 standard)

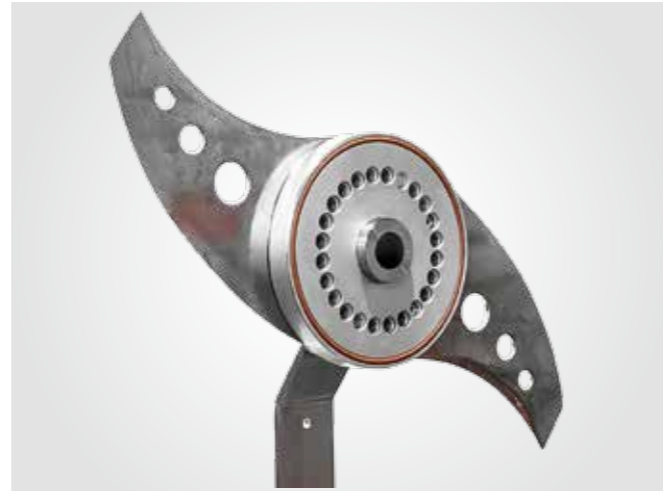

KNIFE BALANCING DEVICE

- › Easy balancing of knife head units
- › Avoids imbalance and vibrations



LOADING FOR 200 LITRE STANDARD TRANSPORT TROLLEY

except for K 65

- › Easy to operate
- › Stainless, hydraulic
- › Robust, low-maintenance, and durable due to hydraulic drive

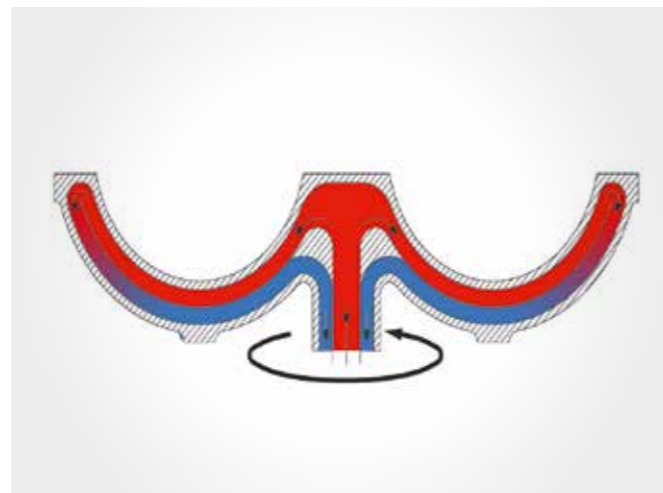

COOKING FACILITY

deliverable only with vacuum version

- › Production of cooked sausage and pies in one process
- › Improved quality due to intense taste
- › No undesired watering
- › Short process times and optimum efficiency factor
- › Savings of personnel costs



LASKA MIXERS

YOUR BENEFITS AT A GLANCE

PRODUCTION

- › Intermeshing paddle mixing shafts for largest possible operating range (including hopper corners)
- › Gentle mixing in, exact and quick distribution of the mixture and its ingredients
- › Ideal, even mixing at consistent quality also in the case of delicate mixtures which can be difficult to mix
- › No smearing caused by „overmixing“ of the mixture
- › Quick, complete, and gentle unloading of the mixture by tilting of the mixing hopper

SERVICE AND MAINTENANCE

- › Minimum maintenance required due to proven field-tested machine concept
- › Easily accessible inspection doors
- › Worldwide service network and support on all continents



HYGIENE AND SAFETY

- › Special double sealing system with cleaning ducts for perfectly hygienic cleaning
- › Polished surfaces for highest possible hygienic standard
- › Safety devices for optimum working safety

OPERATION

- › Easy handling and user-friendly, robust operating elements
- › Automatic mixing to control speed, direction of rotation, and mixing time

ELECTRICAL EQUIPMENT

- › Low current consumption due to state-of-the-art drive and control technology
- › Infinitely variable mixing shaft speed (ME 130 N optional and/or ME 250 N standard)

DESIGN

- › Compact, space-saving design
- › Long service life
- › Low operating noise
- › Attractive, elegant design

EQUIPMENT FOR YOUR TILTABLE MIXER

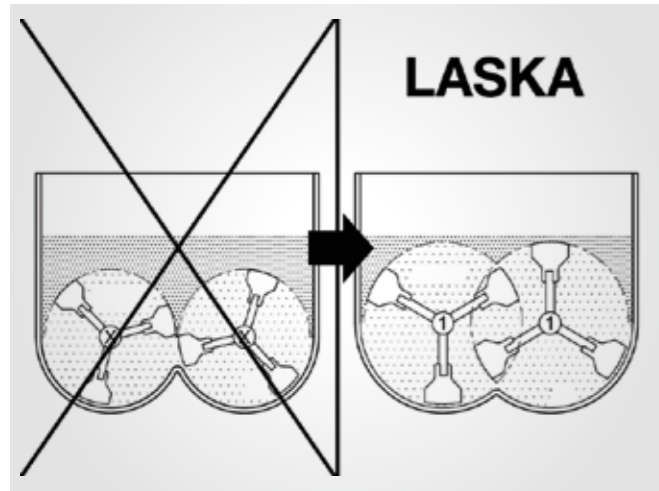

INTERMESHING PADDLE MIXING SHAFTS

- › Large effective area of the mixing shafts in relation to the effective mixing hopper volume



UNLOADING

- › Short unloading time due to tilting of the mixing hopper (compared with mixers with lateral unloading flaps)
- › Excellent unloading of the mixture even in the case of very compact products
- › Therefore no overmixing of mixture on unloading



INFINITELY VARIABLE SPEED OF MIXING SHAFTS

ME 130 N optional / ME 250 N standard

- › Particularly gentle mixing of the material
- › Perfect adaptation of mixing shaft speed to the respective mixture
- › Prevents overmixing of the mixture

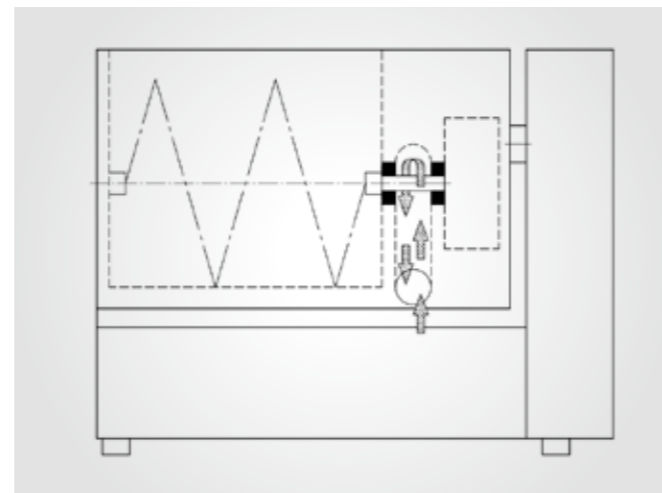

HYGIENE

- › Double sealing of mixing shafts between product and drive areas
- › Product area is reliably protected against the penetration of bearing lubricants and/or gear oils
- › Drive areas are reliably protected against the penetration of product residues
- › Cleaning ducts for perfectly hygienic cleaning



OPTIONS FOR YOUR LASKA MIXER



Z-SHAPED MIXING ARMS

- › Ideal form for tough products that are to be kneaded, e.g. Kebab meat
- › Perfect for mixing of fillings into sausage meat as well as for fluid products
- › Ideal for frequent product changes
- › Especially easy to clean
- › Complete unloading of non-sticking material



CO₂ OR NITROGEN (N₂) REFRIGERATION

- › Via cover or bottom nozzles for various applications
- › Automatic temperature control due to temperature sensor
- › Stainless mixing hopper lid
- › Suction flange



WATER DOSING

- › Automatic addition of freely selectable amount of water
- › Can be preselected and called during production at the push of a button
- › Other liquids than water up to +90 °C can be added



HYDRAULIC LOADING HOIST FOR 200 LITRE STANDARD TRANSPORT TROLLEY

only ME 250 N

- › Stainless, hydraulic
- › Easy to operate
- › Robust, low-maintenance, and durable due to hydraulic drive



VACUUM VERSION

- › Little air entrapped, therefore longer shelf life of products
- › For quality and taste improvement
- › For nice, flesh-coloured, and dense sausage meat
- › Intensive, even reddening
- › Fresh and attractive appearance

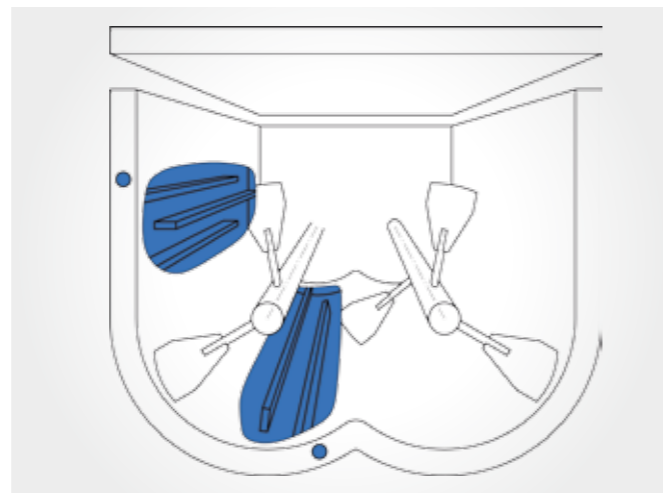

COOKING AND/OR COOLING FACILITY VIA CLOSED STEAM OR COOLING CIRCUIT

only ME 250 N

- › Closed steam or cooling system due to double jacket of mixing hopper
- › Automatic temperature control
- › Electric control
- › Direct steam injection additionally possible



ME 250



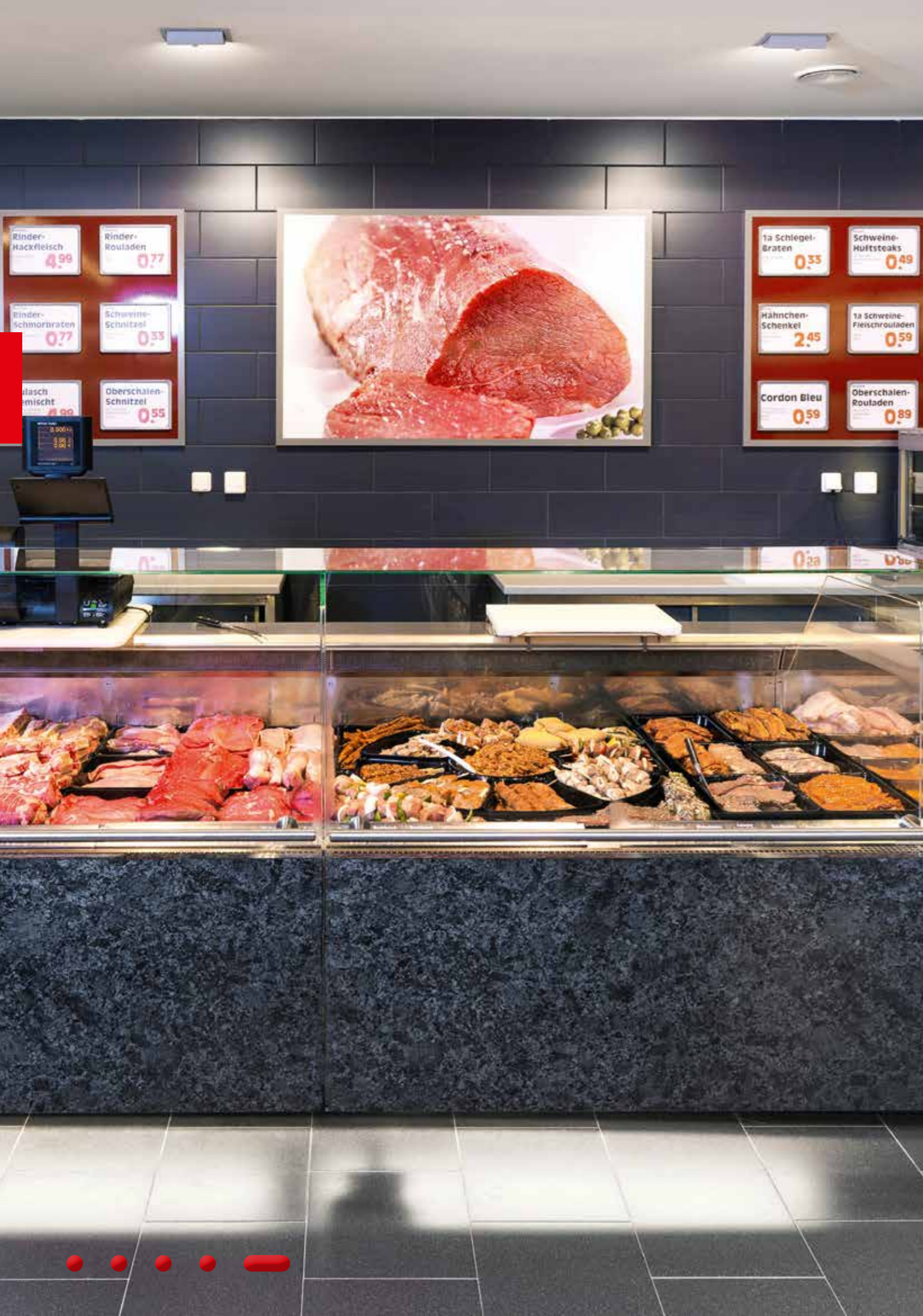

THAT'S WHAT OUR CUSTOMERS SAY



PREM'S BUTCHERY
AUSTRIA

„In LASKA we see a competent partner always using their best efforts and offering excellent machines. In our firm, we had LASKA machines that were already 40 years old. Some years ago we decided to invest in our future and purchased a KU 65 and a W 130 from LASKA.

We'd do this again right away, and we can warmly recommend the machines. The cutter is our pride and joy, and fits in excellently with our firm. We were always attended to promptly and flexibly.“

MS. AND MR. PREM
MASTER BUTCHER AND PROPRIETOR



CARNOSA AG
SWITZERLAND

„We are 100 % satisfied with our angle mincer. The clear and clean cut of the end product, the quiet running, and the low residual amount with frequent batch changes are the most important aspects to us. We process both larger chunks of meat, but also frozen meat for hamburgers on a regular basis.

The machine is very user-friendly, mainly due to the cleaning trolley. In Laska we have found a reliable partner.“

MR. SCHETTER
OPERATIONS MANAGER



REINHARD BAUER, BUTCHERY
GERMANY

„Laska is quite literally the top brand among the machine manufacturers. Because of the good quality of the machines as well as the personal contact with Laska I take much pleasure in my work.

I've been working with my trade machines for more than 10 years. During this time I've had as good as no repair. The mincer needs no stuffing, which facilitates work a great deal for me. And the cutter produces the best emulsion. The loading and unloading facilities are fantastic. Moreover, the machines are very easy to clean.“

MR. BAUER JR.
PROPRIETOR



LASKA PRODUCES MACHINES FOR TRADE AND INDUSTRY MEETING HIGH PRODUCT STANDARDS AND INDIVIDUAL PROCESSING CONDITIONS

TECHNICAL DATA

PERFORMANCE LIST

PERFORMANCE CHARACTERISTICS OF GRINDERS			
TYPE		W 130	WW 130
Holeplate Ø	mm	130	130
Hopper volume standard	ltr	42	175
Motor rating	KW	7,5 11 ³	- 1: 11 - 2: 12,5/15 - G: 15
Nominal output	KW	7,5 11 ³	- 1: 26 - 2: 29 - G: 34
Fuse, slow-blow	A	25 35 ³	- 1: 35 - 2: 50 - G: 50
Feeder cross section	mm ² CU	4 6 ³	- 1: 6 - 2: 10 - G: 10
Safety cover ¹		o (CE)	o (CE)
Cleaning trolley		-	o
Operation		push button	push button
Infinitely variable feed worm		-	o
Automatic speed optimization of the feed worm		-	o (G)
Infinitely variable feed worm and working worm		-	o
Worm ejector		-	o (mech.)
Machine elevation with enlarged hopper 295 l		-	o
Desinewing device	pneum. or mech	o	o
Stirrer ² + enl. hopper	ltr	-	o
Loading hoist		-	o

Data and dimensions without engagement - subject to change.

CAPTION	
•	standard
o	option
-	not available
- 1	1-speed grinder
- 2	2-speed grinder
G	1-speed grinder, frozen meat version
1	for cutting set
2	paddle or Z-arm
3	reinforced version

DIMENSIONS AND WEIGHT					
TYPE		W 130	WW 130		WW 130 ¹
	Length mm L	1220	1350	Länge A	2180
	Width mm B	770	1250	Breite P	1660
	Height mm H	1100	1260	Höhe G	2900
	Height incl. lid mm	1650	2170		
	Weight kg	300	780		850

SEAWORTHY CASE*

	Length mm L	1500	1800		1800
	Width mm B	900	1500		1580
	Height mm H	1390	1650		1890
	Weight kg	130	250		280

* depending on type of transport
¹ incl. loading and required machine elevation

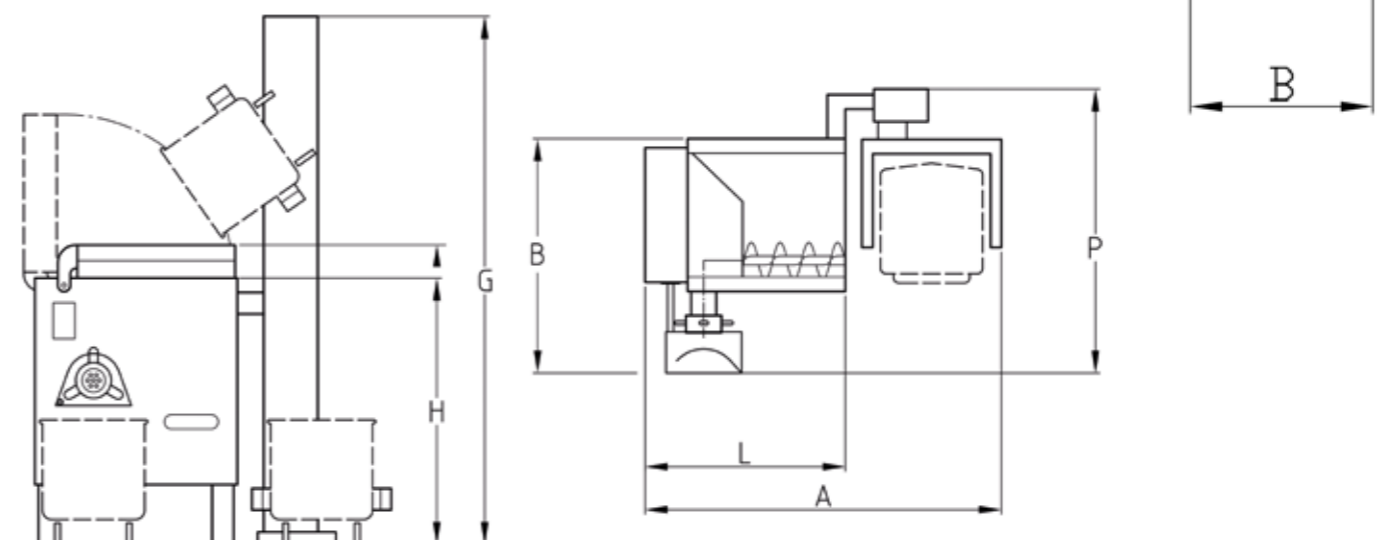

TECHNICAL DATA

PERFORMANCE LIST

PERFORMANCE CHARACTERISTICS OF CUTTER						
TYPE		K 65	K 130	KCU 200	K 60 VAC	K 130 VAC
Bowl volume	ltr	60	130	200	60	130
Motor rating	KW	22	60	90	22	60
Fuse	A	63	125	200	63	125
Feeder cross section	mm ² CU	16	50	95	16	50
Speed knife shaft max.	Upm	5100	4700	4600	5100	4700
Speed mixing cycle max.	Upm	260	240	230	260	240
Knife radius	mm	187,5	240	365	187,5	240
Cutting rate	m/sec	100	120	128	100	120
Bowl speed	Upm	13	13	16	14	14
Suction capacity vacuum pump	m ³ /h	–	–	–	63	100
Ejector		o	o	o	o	o
Knife hood		(man.) ¹	o (pneum.)	(hydr.)	–	(pneum.)
Stainless noise protection cover and/or vacuum cover		o	o	o	(pneum.)	(pneum.)
Cooking facility		–	–	–	o	o
PMS program control		–	–	o	o	o
Touch screen		–	–	–	o	o
Multi-speed version ²		o	o	o	o	o
Balancing device		–	o	o	–	o
Cooling facility		–	–	–	o	–
Forced ventilation		–	–	o	–	–
Water dosing		–	–	o	–	–
Internal control box		•	•	DC	–	–
External control box		–	–	DC o AC	•	•
Loading		–	o	o	–	o

CAPTION			
•	standard	¹	manually operated with lifting assistance
o	option	²	8 + 2 freely programmable knife speeds and/or mixing cycles
–	not available		

Data and dimensions without engagement - subject to change.

DIMENSIONS AND WEIGHT						
TYPE		K 65	K 130	KCU 200	K 60 VAC	K 130 VAC
	Length mm L	1520	2350	2700	1500	2350
	Width mm B	1110	1370	1880	1200	1630
	Height mm H	1140	1270	1380	1300	1450
	Height incl. lid mm	1700	1950	2000	2100	2400
	Weight kg	950	1700	2900	1300	1650

SEAWORTHY CASE*

	Length mm L	1800	2700	3330	1800	2800
	Width mm B	1500	2100	2220	1600	2400
	Height mm H	1500	2100	2240	1500	2300
	Weight kg	300	550	850	300	650

* depending on type of transport

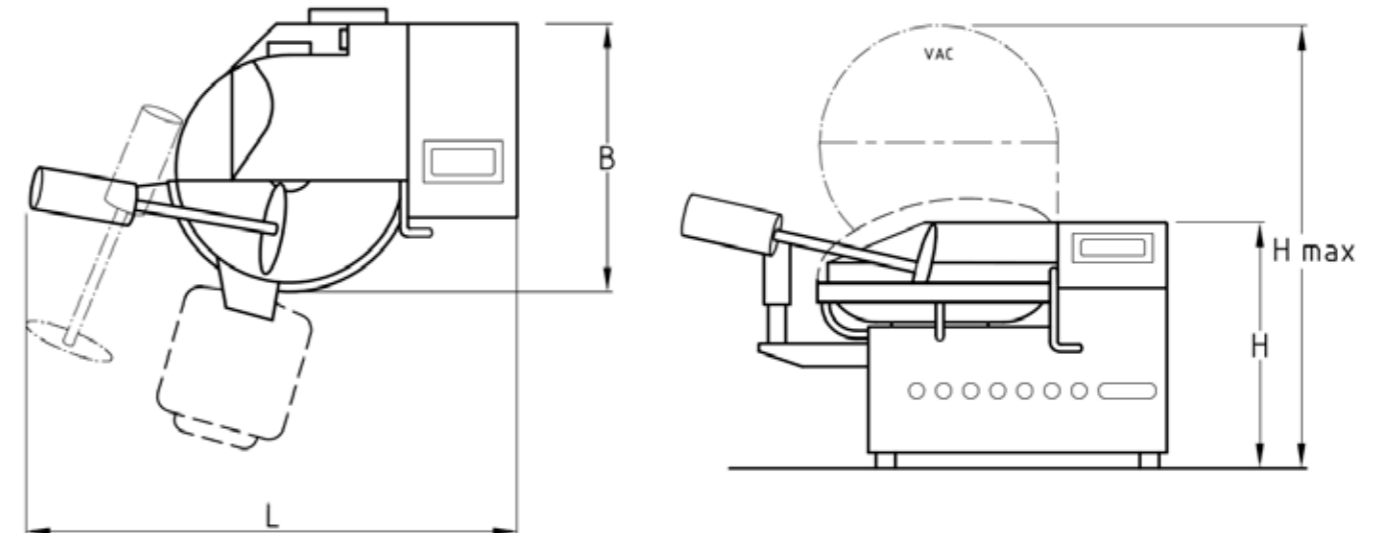

TECHNICAL DATA

PERFORMANCE LIST

PERFORMANCE CHARACTERISTICS OF MIXERS

TYPE		ME 130 N	ME 250 N
Mixing hopper	ltr	130	250
Max. filling quantity	kg	110	200
Motor rating	KW	4	5,5
Fuse	A	20	25
Feeder cross section	mm ² CU	2,5	4
Intermeshing mixing shafts - standard		2 paddles	2 paddles
Intermeshing mixing shafts - option		2 Z-arms	2 Z-arms
Speed of mixing shafts	Upm	55	35
Infinitely variable speed of mixing shafts	Upm	o	•
Vacuum version		o	o
Suction capacity vacuum pump	m ³ /h	63	63
CO2 or nitrogen (N ₂) refrigeration		o	o
Temperature display		o	o
Water dosing		o	o
Cooking and/or cooling facility (closed system)		-	o
Loading hoist		-	o
Automatic tumbling function		o	o
PMS program control		-	o
Automatic mixing function		o	o

Electrical data: degree of protection IP 55

CAPTION

•	standard
o	option
-	not available

Data and dimensions without engagement - subject to change.

DIMENSIONS AND WEIGHT

TYPE		ME 130 N	ME 250 N
Length mm L		1170	1430
Width mm B		730	1200
Height mm H		1450	1920
Height mm D		1740	2770
Height mm G			2600
Weight kg		600	1250

SEAWORTHY CASE*

Length mm L		1300	1600
Width mm B		1300	1500
Height mm H		1600	1850
Weight kg		200	300

* depending on type of transport

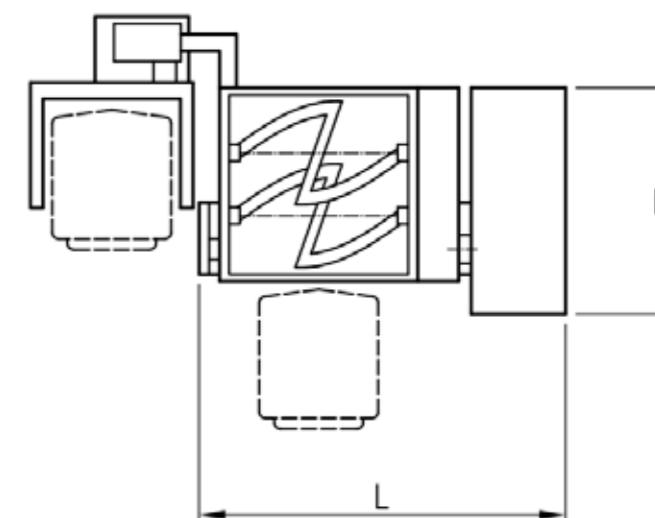
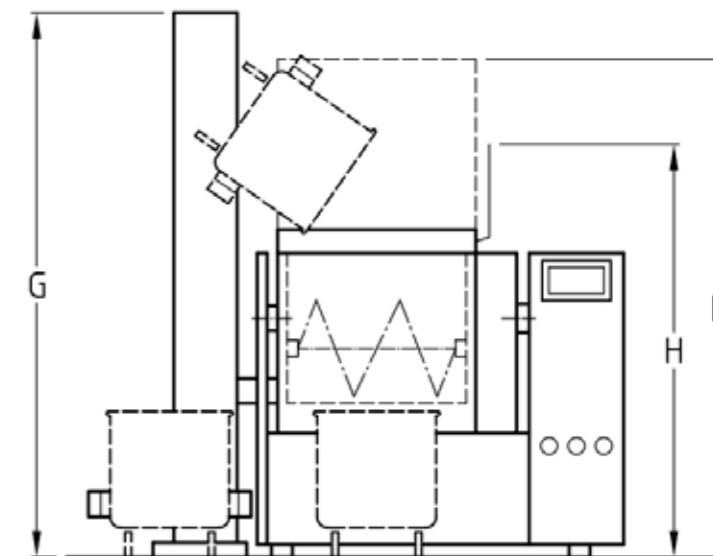

TRADITION & INNOVATION

MORE THAN 130 YEARS OF EXPERIENCE



Since 1880, the family enterprise has been active as a supplier of the food industry and closely associated with the latter. The machines produced by Laska are high-grade products made of stainless steel featuring a number of auxiliary equipment.

Although LASKA is generally known for the best processing of meat, there are numerous other applications in practice, such as the processing of grease, cheese, fruit, vegetable, yeast, pasta, sweets, etc.

Today, LASKA machines are famous for their high quality in more than 130 countries on all continents, where they work to the complete satisfaction of national and international customers.

OUR PRODUCT RANGE:

- Cutters
- Grinders & mixer-grinders
- Frozen meat cutters
- Emulsifiers
- Mixing machines
- Production lines



Maschinenfabrik LASKA Gesellschaft m.b.H.

Makartstraße 60, 4050 Traun – Austria

P +43 7229 / 606-0

F +43 7229 / 606-400

laska@laska.at

www.laska.at

DEALER/PARTNER

